

Power Conversion System

JKP-100LN-BA

User Manual

Zhejiang Jinko Energy Storage Co., Ltd.

Statement

Dear Users,

Thank you for choosing our products! Please take the time to read this User Manual thoroughly before using the product.

By carefully reviewing this manual, you will gain a better understanding of the product's features, how to use and maintain it correctly, and ensure its safe operation and optimal performance, allowing you to achieve the maximum benefit.

The images included in this manual are for illustrative purposes only. Actual details may vary slightly depending on the product version and market region. This manual has been prepared based on the energy storage system's specifications at the time of commissioning. As the product evolves, both the form and technical specifications may change. Future updates to the manual will reflect these changes, but these revisions will not be specifically communicated.

Please note: If the system fails due to negligence, improper use, or unauthorized tampering with the control program, warranty rights will be forfeited. Our after-sales service will not accept any direct or indirect warranty claims arising from such circumstances.

The copyright of this manual is owned by Jinko Solar Co., Ltd. Reproduction or distribution by electronic, mechanical, or other means is prohibited without prior permission from the company.

Contents

User Manual	1
Statement	2
Contents	3
Glossary	4
Safety Instructions	4
1. Product Introduction	10
2. External Layout and Definition of Connection Terminals	11
3. Overview of System Operating Status	14
4. Product Installation	15
5. Product Wiring	17
6. Installation and Wiring Checklist	24
7. Start-up and Shutdown Process	26
8. Remote Control from the Computer	28
9. Transportation	33
10. Storage	34
11. Maintenance and Repair	35
12. Routine Maintenance	36
13. Technical Parameter	37
14. Quality Assurance	39









晶科密级: 商密AA
Classification: L2

Glossary

- AC [Abbreviation for "Alternating Current"]
- DC [Abbreviation for "Direct Current"]
- Energy [Energy is measured in Wh (watt hours), kWh (kilowatt hours), etc]
- PCS [Power Conversion System]
- PE [Protective Earth]
- PPE [Personal Protection Equipment]
- IP [Ingress Protection Level]
- IO [Input and Output]
- HV [High Voltage]

Safety Instructions

Table 1-1 Symbols, Terms and Names Used

	<p>Danger!</p> <p>Hazard at high risk level, which will lead to death or serious injury if it is not avoided.</p> <p>Follow the manual requirements to prevent serious accidents and fatal injuries.</p>
	<p>Warning!</p> <p>Hazard at medium risk level, which will likely lead to death or serious injury if it is not avoided.</p> <p>Only qualified professionals can carry out installation and maintenance.</p>
	<p>Caution:</p> <p>Hot surfaces! Risk of burns. Surface temperatures may exceed 60°C.</p>
	<p>For both AC and DC power terminals after disconnection wait at least 60 minutes before performing any maintenance.</p>
	<p>PE Grounding</p> <p>The protective grounding (PE) terminal must be securely grounded during installation to ensure personnel safety.</p>
	<p>Compliance with CE Certification Mark</p>
	<p>Read the instructions before performing any operation on the equipment.</p>
	<p>Disposal Notice</p> <p>The PCS must not be disposed of as domestic waste. Please handle it in accordance with local regulations for electronic equipment disposal.</p>

Safety Guidelines

Before installing and debugging the equipment, be sure to read these precautions and some safety precautions to be observed when operating and maintaining the converter. For specific safety instructions in use and maintenance, please refer to the safety instructions in corresponding chapters.

Before operation, please carefully read the notes and precautions in this part to avoid accidents.



“Dangers”, “warnings” and “precautions” in the manual do not represent all safety precautions to be observed, but only serve as a supplement to safety precautions in various operations.



Jinko is not liable for any violation of general safe operation requirements or safety standards for the design, production and use of equipment.

Safe Use Instructions



Do not touch any terminals or conductors connected to the Power grid circuit, otherwise it may lead to fatal danger!



There are no user-operated parts inside the equipment, so please do not open the machine shell without authorization, otherwise there will be the danger of electric shock, and the resulting equipment failure is not covered by the warranty.



After disconnecting the input and output of the converter, the energy remaining in the energy storage capacitor of the converter may still cause electric shock. Ensure that all Power supplies are turned off for 30 minutes before maintenance can be carried out.



Do not put your fingers or tools into the running fan, so as not to endanger personal safety or damage equipment.



The surface temperature of the converter may reach 75°C. Please avoid contact with its surface when it is working, otherwise it may cause scalding.

**Note**

Do not allow liquid or other foreign objects to enter the machine, otherwise it may cause damage to the machine.

**Warning**

In case of fire, please use dry powder fire extinguisher. If you use liquid fire extinguisher, you will be in danger of electric shock.

Energy Storage Battery Protection

There is a fatal high voltage between the positive and negative electrodes of the energy storage battery pack, which may lead to electric shock danger and even endanger life safety.

**Danger**

During equipment maintenance, ensure that the connection between the converter and the energy storage battery pack is completely disconnected, and set a warning sign at the disconnection to ensure that it will not be accidentally reconnected.

Electrostatic Protection

**Note**

Electrostatic electricity generated by human body may cause damage to sensitive devices on printed boards. Before touching sensitive components, wear an anti-static bracelet and ground the other end of the bracelet well.

Grounding Requirements

**Warning**

High leakage current danger! Before electrical connection, grounding must be ensured. The grounding terminal must be connected to the earth. Otherwise, there may be electric shock danger when touching the machine.

When installing equipment, it must be grounded first; when dismantling the equipment, the ground wire must be removed last.

- It is forbidden to damage the grounding conductor.
- The equipment must have permanent grounding protection.
- Before operating the equipment, verify the electrical connections to ensure it is reliably grounded

Moisture Protection



Moisture invasion may cause converter damage!

In order to ensure the normal use of the converter, please follow the following instructions:

- When the air humidity is >95%, please do not open the cover plate of the converter;
- Under rainy or humid weather conditions, avoid opening the converter door panel for maintenance or overhaul.
- It should not be used directly in the open air in coastal or desert areas with high salt fog and high dust

Safety Warning Sign Placement

To avoid accidents caused by irrelevant personnel approaching or mis operating the converter, please comply with the following relevant specifications during installation and daily maintenance and overhaul of the converter.

- Set warning signs at the front and rear switches of the converter to prevent accidents caused by wrong closing.
- Set warning signs or safety warning belts in the operation area to avoid personnel injury or equipment damage caused by irrelevant personnel entering.

Electrical Connections

Electrical connection must be carried out in strict accordance with the description and electrical wiring schematic diagram in this manual.



Technical parameters such as battery configuration, Power grid grade and frequency must meet the technical parameters of converter. Grid-connected operation shall be allowed by the local Power supply department and professionals shall be invited to carry out relevant operations.

All electrical connections must meet the electrical installation standards of the country/region where the project is located.

Live voltage measurement



Dangerous high voltage is present, accidental touch may lead to fatal electric shock risk. Therefore, during live line measurement, appropriate personal protection equipment (PPE) needs to be used (insulating gloves and other PPE as required).

The measuring equipment must meet the following requirements:

- The measuring range and operating conditions of the equipment must meet field requirements.
- The connection of the measuring equipment must be correct and standardized to prevent hazards such as arcing.

Operator Requirements



The operation and wiring of the converter shall be performed by qualified personnel to ensure that all electrical installations comply with electrical installation standards.

Professional and technical personnel must meet the following requirements:

- Complete dedicated training to understand safety precautions and master proper operating methods.
- Have a thorough understanding of the design and working principles of the entire energy storage system.
- Be familiar with the relevant standards applicable to the country and region where the project is located.

Important Considerations During Maintenance or Overhaul



After the AC and DC sides of the Power Conversion System are disconnected, it is necessary to wait for at least **60 minutes** (1 hour) before maintenance or overhaul.

After the Power Conversion System was shut down, it has been out of operation. When maintaining or overhauling it, pay attention to the following matters:

- Use a multimeter to verify that no voltage is present inside the converter.
 - Establish the necessary grounding connections.
 - Cover any parts that may be electrified near the operating areas with insulating materials.
 - Throughout the maintenance and overhaul process, ensure the escape route remains completely unobstructed.
 - Ensure that the converter is not accidentally repowered.
-

Additional Considerations



All operations on the converter must meet the relevant standards of the country/region where the project is located.



When the equipment is electrified, it is strictly forbidden to carry out maintenance or overhaul operations!

During maintenance or overhaul, at least two personnel must be present. Maintenance operation can be carried out only after the equipment is completely **powered off** and there is **no voltage** present

In addition, the following protective or emergency measures shall be implemented based on site

requirements:

- Operators shall take appropriate protective measures, such as wearing anti-noise earplugs, heat-resistant gloves, and insulated shoes.
- The corresponding emergency rescue facilities shall be notified and available when needed.
- Implement all necessary additional measures to ensure the safety of both personnel and equipment.

晶科密級: 商密AA
Classification: L2

1. Product Introduction

The main function of the JKP-100LN-BA Power Conversion System (PCS) produced by Jinko is to charge and discharge battery components, convert direct current (DC) into sine wave alternating current (AC) that meets the requirements of the power grid. It can also charge the electricity from the power grid into the battery, making it an important part of the SunGiga energy storage system.

JKP-100LN-BA has protection functions, such as island protection, DC overvoltage protection and AC overvoltage/undervoltage protection, etc., to meet the grid-connection/grid- disconnection requirements. Internal topology of the PCS is shown in Figure 1-1.

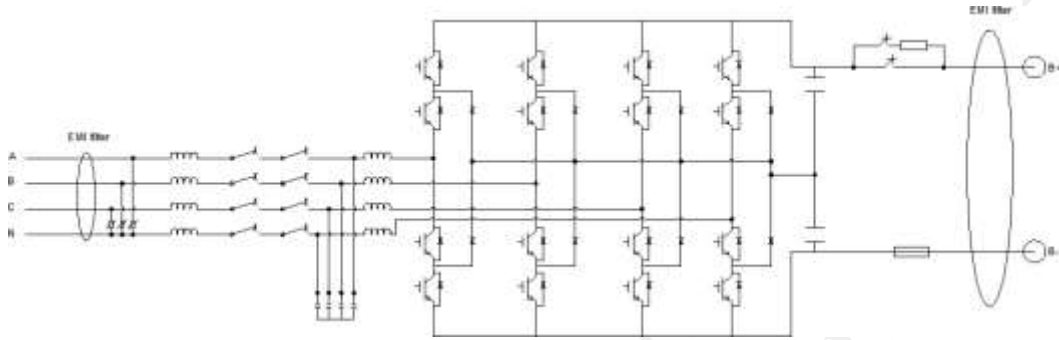

Figure 1-1 Topology of the JKP-100LN-BA

Permitted mode of operation: On-grid only.

1.1. Grid-Connected Operation

Unless otherwise specified, the Jinko JKP-100LN-BA PCS can operate normally under the following power grid conditions:

- The harmonic voltage limits set by local, national, and power grid standards and regulations.
- The three-phase voltage imbalance at the AC output terminal limits set by local, national, and power grid standards and regulations.
- The allowable deviation in grid voltage set by local, national, and power grid standards and regulations.
- The allowable deviation in grid frequency set by local, national, and power grid standards and regulations.

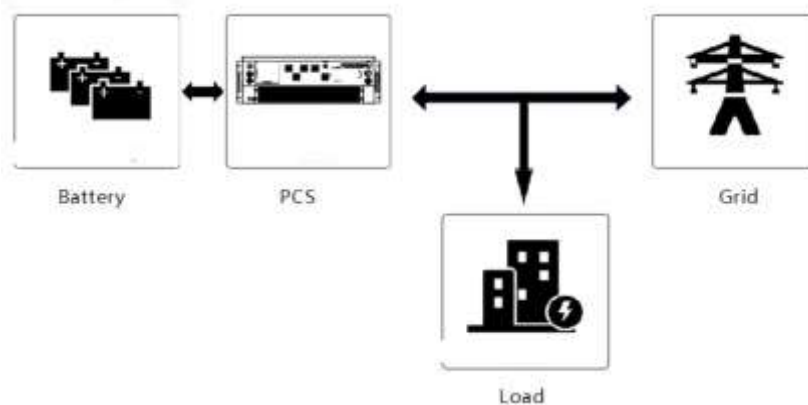

Figure 1-2 Connection block diagram of the JKP-100LN-BA

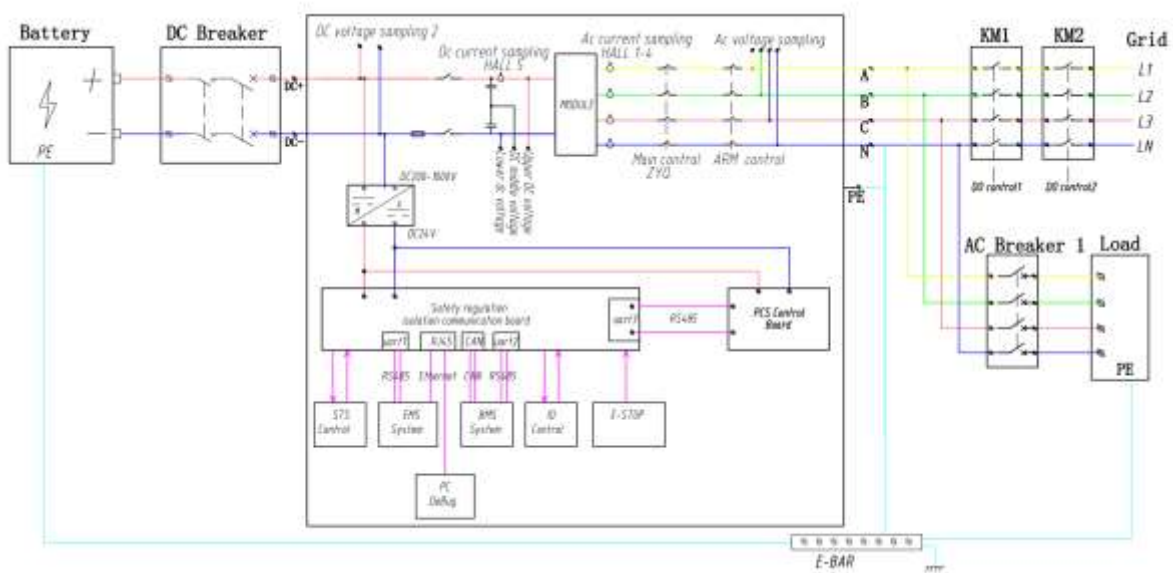

Figure 1-3 System diagram of the JKP-100LN-BA

1.2. Inbuilt protection functions.

The system includes protection for overvoltage and undervoltage, high and low frequency of the power grid, as well as DC overvoltage, undervoltage, overcurrent, and polarity reverse protection.

It also provides AC overcurrent protection, overtemperature protection, phase loss protection, anti-islanding protection, AC incoming phase sequence error protection, communication fault protection, and cooling system protection.

2. External Layout and Definition of Connection Terminals

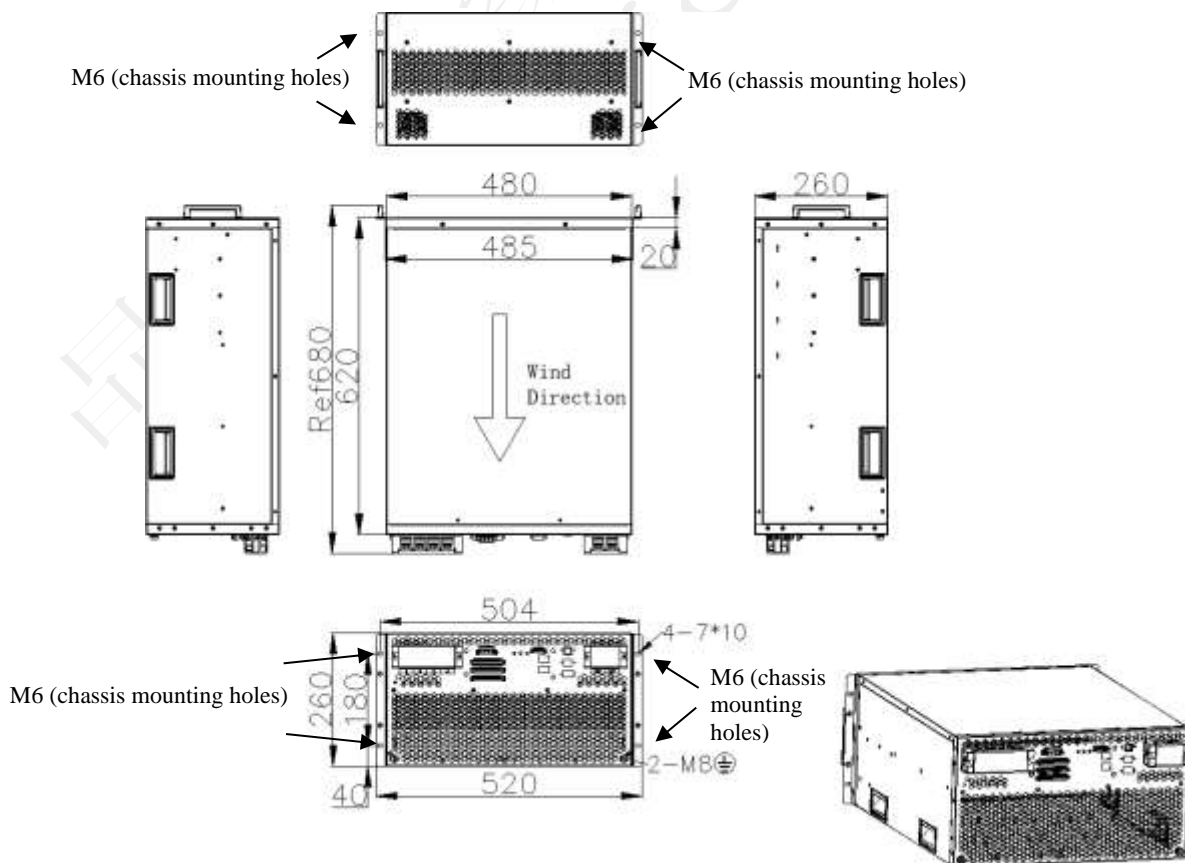

Figure 2-1 Dimension of the JKP-100LN-BA



Figure 2-2 Front side view of the JKP-100LN-BA

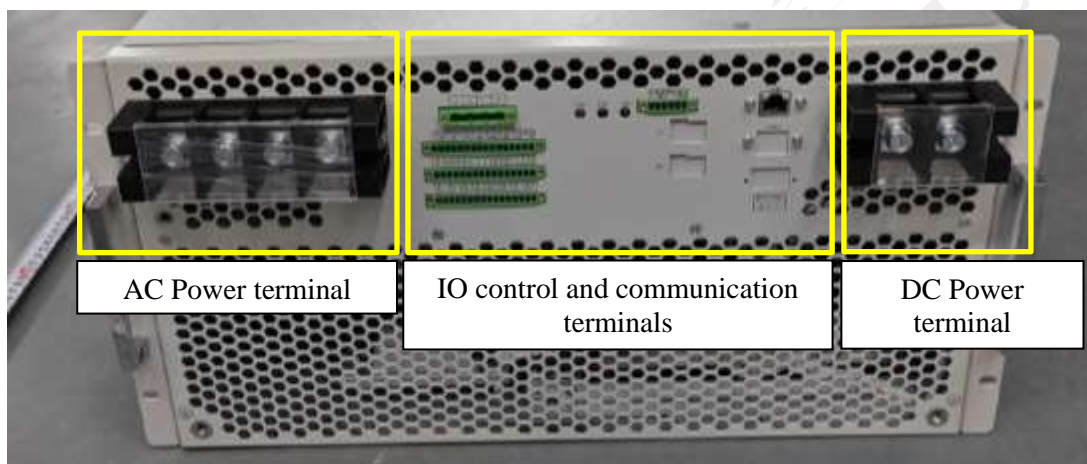

Figure 2-3 Rear side view of the JKP-100LN-BA

The external connection points of JKP-100LN-BA include:

- AC Power input and output terminal
- DC Power input and output terminal
- IO control & communication interface

2.1. Terminal definitions

AC Power input and output terminal

This terminal has 4 x AC cables connection points for [A, B, C] phase cables and [N] neutral cable.

These cables are connected to the 3-phase AC MCCB of the SunGiga. The minimum cross-sectional area of the cable is 70 mm².

DC Power input and output terminal

This terminal has 2 DC cable connection points for [DC-, DC+] cables. These cables are connected to the respective battery terminals.

In the SunGiga design, these cables are first connected to the “HV box” which houses the fusing and disconnection devices, before being connected to the battery terminals. The minimum cross-sectional

area of the cable is 50 mm².

IO control and communication terminal

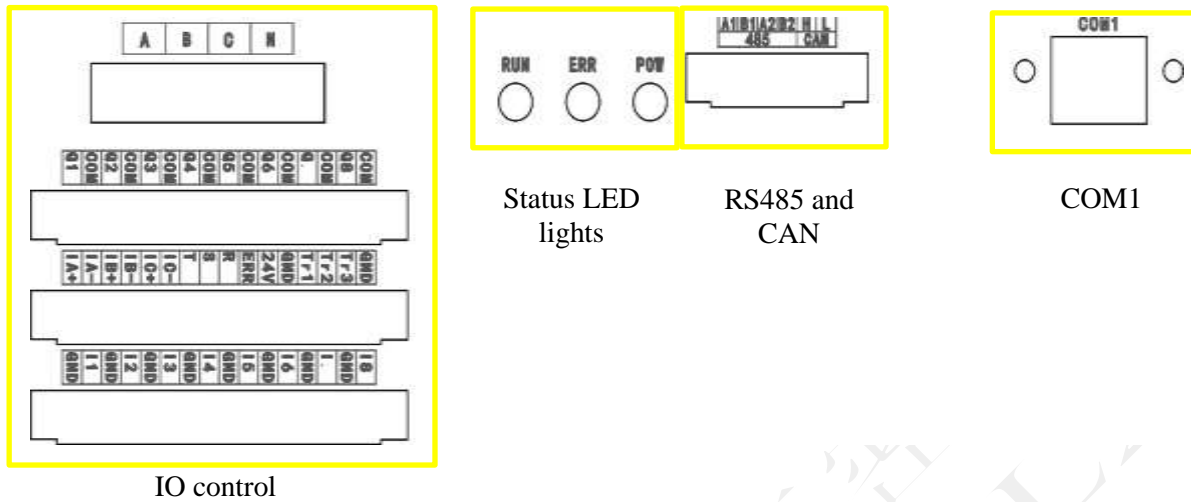

Figure 2-4 IO control and communication interface definitions

Table 2-1 IO Control and communication interface definitions

No.	Part Name	Notes
1	COM1	COM1 is used for Jinko EMS connection and debugging.
2	CAN, 485-1/2	The CAN port is used for Jinko BMS connection. RS485-1/2 ports are reserved.
3	Pin number	
	[I]	Digital Input definition [24V to GND]
	1	Emergency Stop (DRM0)
	2	Reserved. (BMS fault detection)
	3	Reserved. (STS over temperature signal)
	4	Reserved. (Smoke \fire and humidity detection)
	5	Reserved. (AC soft start detection)
	6	Reserved. (AC main contactor detection)
	7	Reserved. (Parallel high-speed synchronization)
	8	Reserved. (Spare)
	[Q]	Digital Output definition [24V to COM]
	1	Reserved. (Cabinet fan control)
	2	Reserved. (Fault output dry contact
	3	Reserved. (Grid-connected and grid disconnected contactors)
	4	Reserved. (Spare)
	5	Reserved. (AC soft start contactor)
6	Reserved. (AC main contactor)	
7	Reserved. (Parallel high-speed synchronization)	
8	Reserved. (Spare)	
4	IA+, IA-, IB+, IB- IC+, IC-	Reserved. (Current sampling signal for grid-connected and switching requirements, grid-connected and grid-disconnected switching switches).
5	T, S, R,	Reserved. (Spare, no wiring)
6	ERR	Reserved. (The fault indicator signal for STS, which may not be

		connected).
7	Tr1, Tr2, Tr3, GND	Reserved. (GND: GND of trigger signal; Tr1, Tr2, Tr3: Trigger signals of STS, which can be connected with only one phase)
8	A/B/C/N	Reserved. (Voltage sampling on Power grid side is generally used with grid- connected and grid-disconnected switching cabinets)

2.2. Demand Response Enabling Device (DRED) and Demand Response Mode (DRM)

The inverter has a means of connecting to a DRED via terminal block.

Only DRM0 supported (operate the disconnection device). Connect PIN I1 to its GND for DRM0.

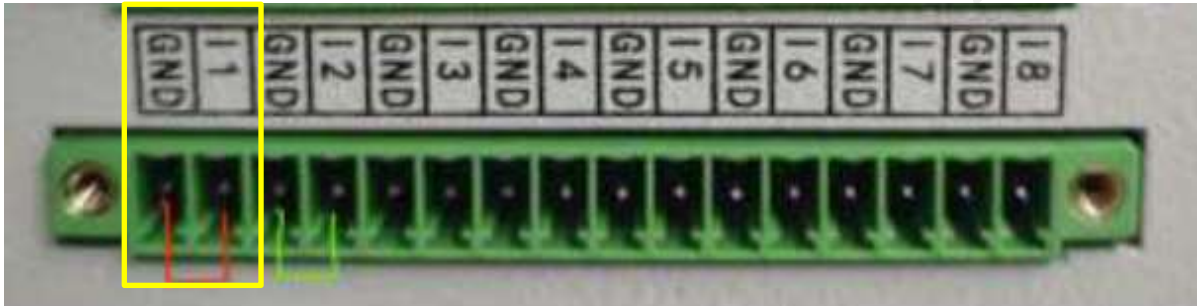

Figure 2-5 DRM0 connection block

3. Overview of System Operating Status

3.1. Status LED

The JKP-100LN-BA features three LED indicators located at the middle and upper sections of the unit (see Figure 2-4). These LED lights display the operational status of the equipment, allowing the current working state to be determined by whether the indicators are in ON or OFF state.

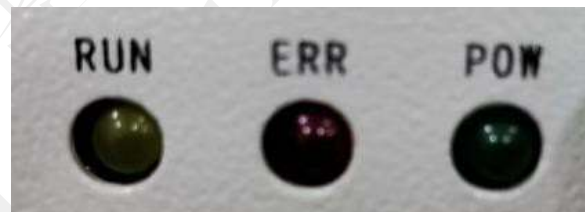

Figure 3-1 Outline Diagram of Indicator Light

No.	Indicator Light	Notes
1	POW	(Power) During normal operation, the indicator light remains continuously ON. In standby mode, the indicator light flashes.
2	ERR	(Error) The indicator light is always ON during failure
3	RUN	(Running) The indicator light is always ON when DC is connected

3.2. Standby status

Standby status refers to the state where the grid-connected JKP-100LN-BA is powered on and waiting to receive operational instructions

When the operation instruction is to charge (i.e., specifying a constant voltage charging value, constant current charging value, or constant power charging value), the charging mode—constant voltage, constant current, or constant power—must first be determined. Once determined, the system enters the grid-connected charging status.

Similarly, when the operation instruction is to discharge (i.e., specifying a constant current discharge value or constant power discharge value), the discharge mode—constant current or constant power—must first be determined. Once determined, the system enters the grid-connected discharge status

3.3. Fault status

When the JKP-100LN-BA detects a failure, it will communicate the fault status to the BMS and will immediately both the AC and DC side of the PCS, entering fault status to ensure system safety. The JKP-100LN-BA will continuously monitor the fault status, and if the fault is not resolved, it will remain in fault status.

4. Product Installation

4.1. Required Accessories

Quantity	Accessory Name	Description
1	PCS communication harness	to connect BMS and EMS to the PCS, refer to section 5.6 “BMS and EMS connections
8	M6 bolts	Required for PCS Chassis Mounting
2	M8 bolts	Required for PE cable connection

1.1. Required Tools

The following tools and parts are required for installation:

- Torque wrench (M8, M6, torque 120 ± 1.5 kgf/cm)
- Screwdriver
- Wire stripper
- Terminal crimping tool
- Megohmmeter and multimeter

1.2. Installation Conditions

To ensure the proper operation of the equipment, the following general environmental installation requirements must be met:

- The ingress protection grade of the JKP-100LN-BA is IP20. As electronic equipment, it must not be placed in wet or flooded locations.
- Install the equipment under cover to avoid exposure to direct sunlight and rain.
- Ensure good ventilation around the equipment.
- The installation environment must be clean.
- The equipment generates some noise during operation; therefore, it should be installed away from residential areas.
- Ensure that the installation ground is stable and does not shake. The supporting surface must meet the load-bearing requirements of the Power Conversion System.
- The installation location must allow for easy maintenance.
- The ambient temperature should range from -20°C to $+60^{\circ}\text{C}$.
- Sufficient space must be reserved around the equipment to ensure proper ventilation and heat dissipation

1.3. Requirements for Positioning

The unit must be installed horizontally and must not be installed upside down or on its side.

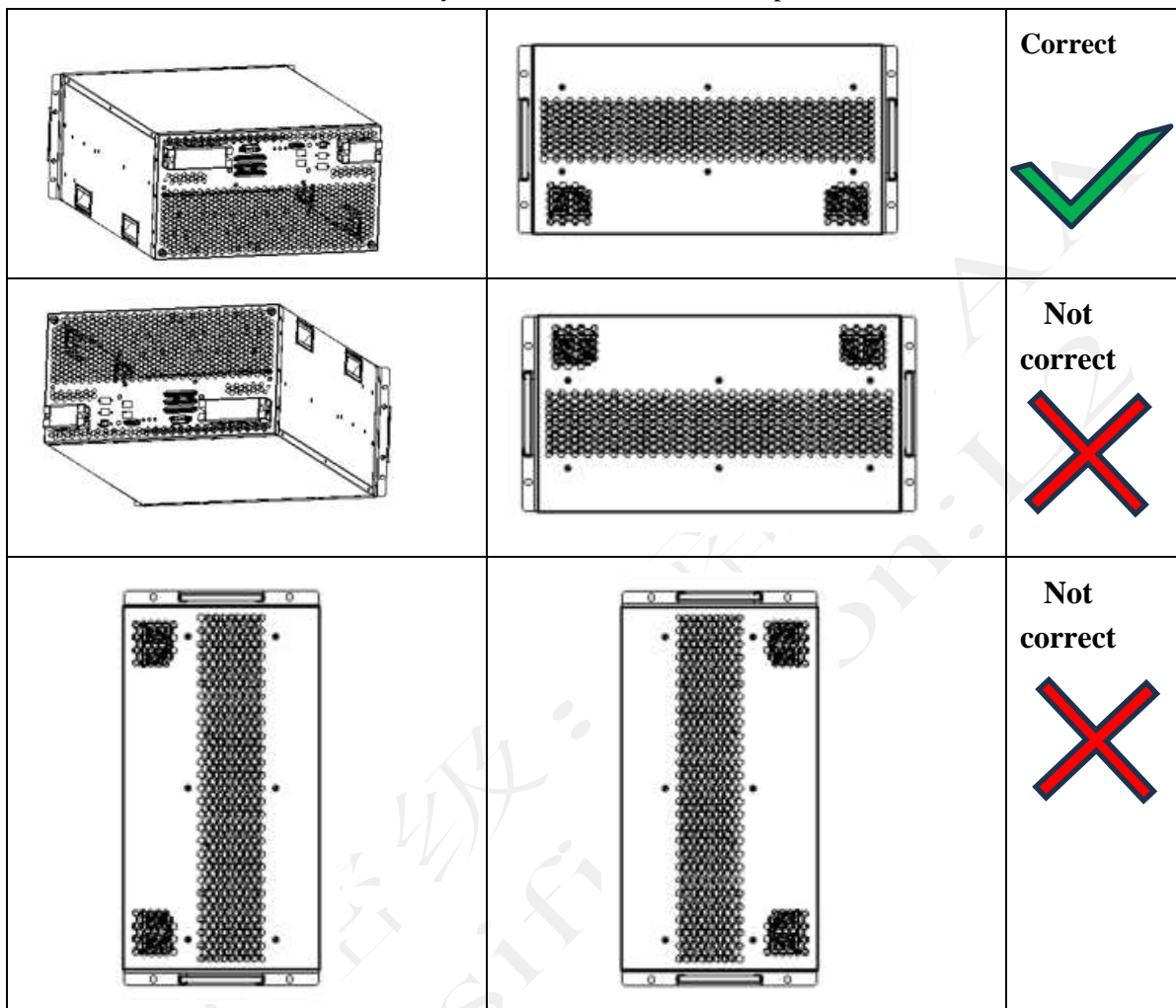

Figure 4-1 Installation requirements

1.4. Requirements for Ventilation

JKP-100LN-BA is equipped with internal cooling fans. Therefore, it is necessary to fully consider the release of the heat when designing the chassis to ensure the normal and efficient operation of the equipment.

In order to meet the ventilation requirements of JKP-100LN-BA, the installation environment of ventilation equipment shall meet the following conditions:

- Power Conversion Systems shall not be installed in places with poor ventilation conditions and low air flow.
- The air inlet shall be replenished with sufficient air.
- It is necessary to ensure that the air inlet area is equivalent to the front panel area of JKP-100LN-BA, and an exhaust fan is added to the air outlet.
- Ensure that the air inlet and outlet of JKP-100LN-BA are unobstructed and there is no return air.

1.5. Requirements for Spacing

When installing JKP-100LN-BA, keep proper distance from other equipment to meet operation and maintenance requirements.

- Front and back (airflow clearance): 295 mm
- Left and right sides: 195 mm
- There is no min clearance from top (above) and bottom (underneath).

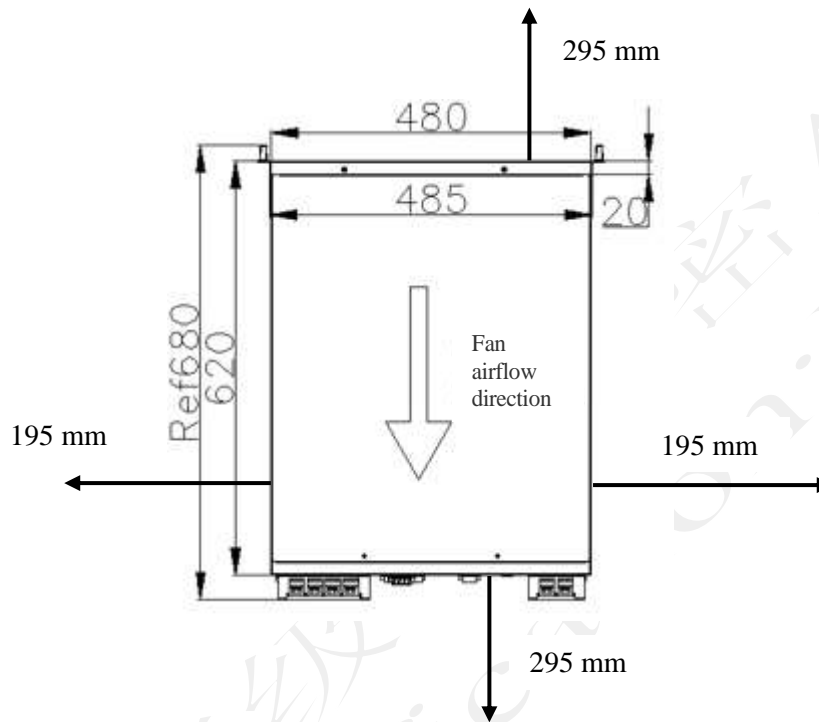

Figure 4-2 Spacing requirements

1.6. Requirements for Chassis Mounting

When installing the PCS into the cabinet, ensure it is securely placed on the horizontal plate, and the mounting plates of the PCS are firmly bolted to the cabinet frame.

The JKP-100LN-BA has 4 mounting holes located on the front and back sides of the PCS, designed for M6 bolts (Torque is 6 N·m.). Mounting bolts are not supplied.

For the exact locations of the mounting holes, refer to Figure 3-1 and Figure 3-2.

2. Product Wiring



Danger!

High voltage electric shock hazard present during operation of the JKP-100LN-BA. Only qualified electricians with professional skills should operate and perform wiring of the device.

All connections to the device must be made when the system is powered off.

Incorrectly connecting input and output terminals may cause permanent damage to the JKP-100LN-BA.

Failure to follow these warnings could result in severe personal injury, significant property damage, or even death.

2.1. Battery Specification

The JKP-100LN-BA is only suitable for use with Jinko Li-ion batteries, specifically the JKPK-43K-1P48S-LAA series.

The positive and negative open-circuit voltage of the battery assembly must not exceed 900V DC.

Note: [DC-, DC+] battery connection port is internally protected with a fuse. Fuse ratings are $I_{rated}=350A$, I^2t (prearcing) = 31.5kA, I^2t (clearing) = 135kA, power dissipation = 90W. The fuse's prearcing integral value vs time is given below.



图 Figure 2



图 Figure 5

For short external circuit protection, the JKP-100LN-BA should be connected to the battery system through a circuit breaker. The recommended values for the external DC circuit breaker are 225-300A, $I_{cs} > 30kA$.

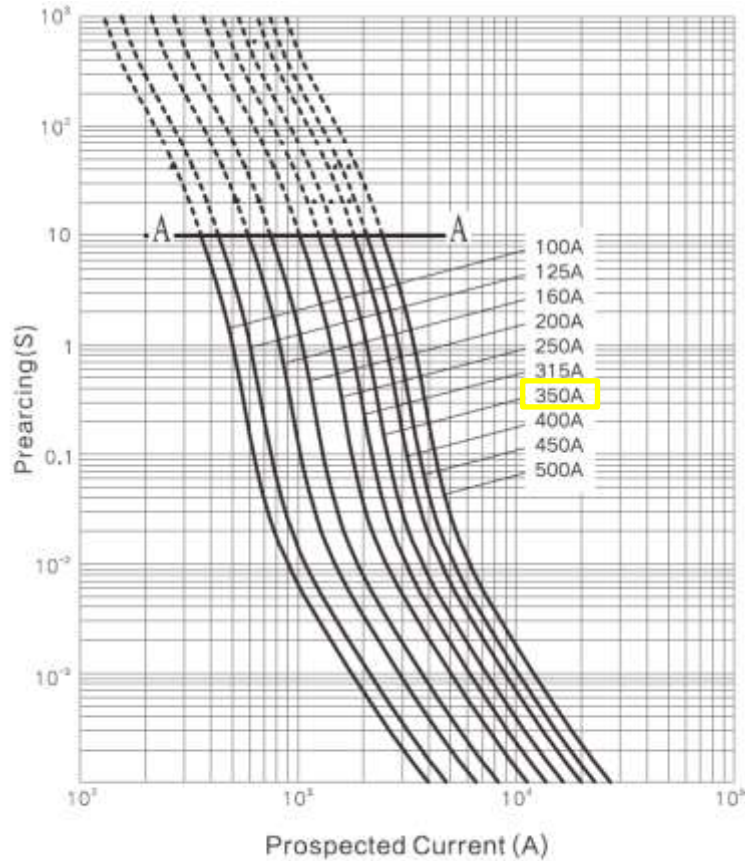
It is recommended that the insulation resistance between BT+ and BT- to ground at the DC terminal should be greater than 10 M Ω .

JKP-100LN-BA does not have temperature sampling functionality. Battery control must be managed by the pre-programmed Jinko BMS. Refer to Section 4.1 “IO control and communication terminal” for pinout and connection details.

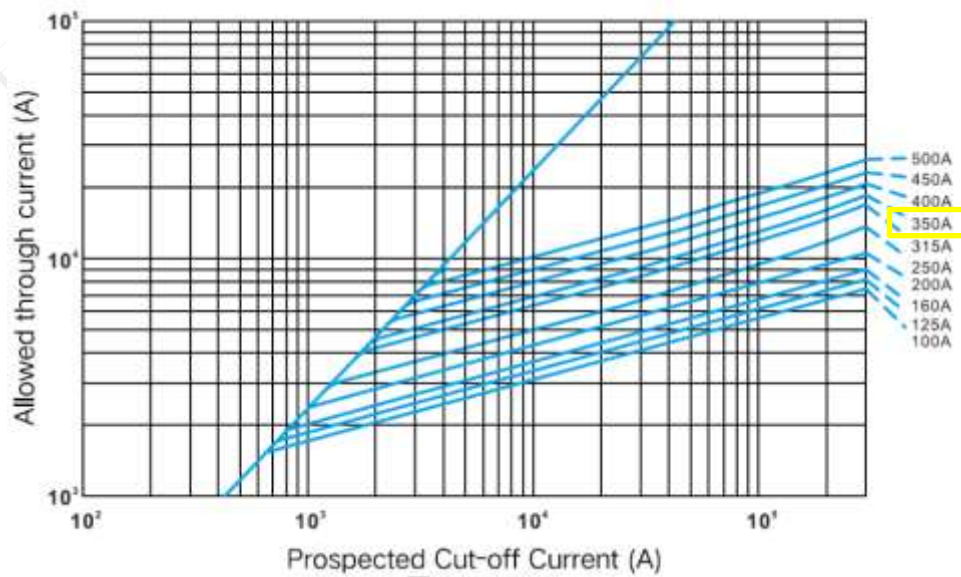
For more detailed battery specification refer to Section 9 (Technical Parameters).

2.2. Three-phase network

The JKP-100LN-BA is certified in accordance with AS4777.2 and is suitable to be connected in Australia and New Zealand. Region settings (Australia A, Australia B, Australia C and New Zealand) refer to Section “Remote Control from the Computer”.

Recommended values for the external AC circuit breaker are 400V, 250A, $I_{sc} > 25kA$, 3 Poles.

For more detailed specification of the suitable power network parameters refer to Section “Technical Parameters”.

2.3. RCD

External RCDs are not included in JKP-100LN-BA product supply list. If required, the following RCD specification can be used for equipment selection:

- Rated voltage: 400VAC
- Rated current: 200A
- Type: A or AC
- Residual operating current: 30mA

2.4. Cable requirements

Table 5-1 Cable and wiring requirements

Model	JKP-100LN-BA	
Mounting aperture	<p>AC side M8 type wire pressing terminal, DC side M8 type wire pressing terminal, and M8 type wire pressing terminal for PE.</p> <p>The recommended tightening torque is 7 to 10 N·m. For AC and DC wiring cables, the stripping length should be 19-21 mm, and the crimping length should be 12-14 mm.</p> 	
Battery assembly BT+ (DC+)	$\geq 50 \text{ mm}^2 * 1$	BT+
Battery assembly BT- (DC-)	$\geq 50 \text{ mm}^2 * 1$	BT-

Power grid	$\geq 50 \text{ mm}^2 * 4$	ABCN (phases and neutral)
PE grounding protection	$\geq 25 \text{ mm}^2 * 1$	The cross-section of the PE wire should be of the same material as the ADCN wire and not less than 1/2 of the cross-sectional area of the phase conductor Torque: $15 \pm 1 \text{ N} \cdot \text{m}$
Model	JKP-100LN-BA	
Secondary harness (Reserved and not used)		
Secondary signals (except IA+, IA-, IB+, IB-, IC+ and IC-)	$\geq 28 \text{ AWG} * N$	Secondary signal harness
IA+, IA-, IB+, IB-, IC+, IC-	$\geq 18 \text{ AWG} * 6$	STS current sensor

2.5. Preparation Before Electrical Wiring

Before proceeding with the wiring, ensure the following:

- The JKP-100LN-BA is in shutdown status, with no voltage present on the AC and DC sides, and the panel indicator light is OFF.
- The AC side incoming isolation switch is in the open position.
- The battery side isolation switch is open.
- Perform the wiring operation only after confirming the above DC side wiring

2.6. BMS and EMS connections





It is design for only Jinko prefabricated communication harness to be connected the PCS.

Refer to Figure 2-4 for IO control and communication interface definitions.

Refer to Table 5-2 below for connection details.

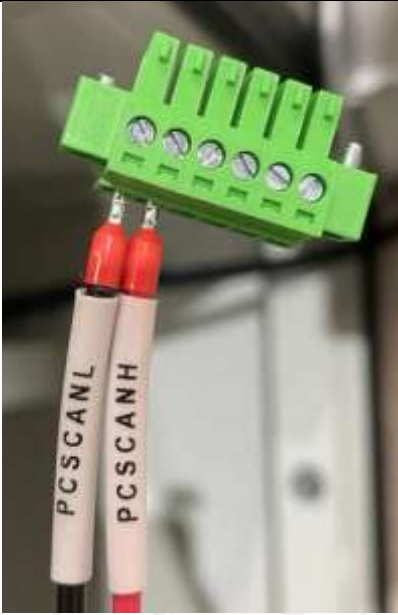
Table 5-2 Installation instruction and correct

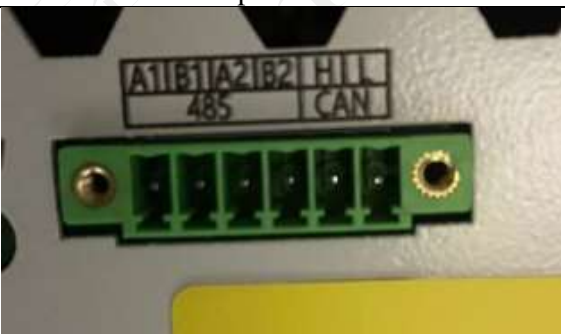
EMS connection	BMS connection
Connect the supplied prewired EMS communication harness to the COM1 port.	Connect the supplied prewired BMS communication harnesses to the CAN port

	
<p>RJ45 cable for the EMS connection</p>	<p>Correctly install the CAN L (labelled PCSCANL) and CAN H (labelled PCSCANH) wires into the 6-pin connection terminal</p>
	
<p>COM1 RJ45 cable connection for the EMS cable</p>	<p>6 PIN terminal for CAN connection. Two rightmost pins are marked CAN H and CAN L connection.</p>
	
<p>Correct installation of the EMS cable to the PCS.</p>	<p>Correct installation of the CAN H and CAN L wires to the PCS.</p>

2.7.DC Side Wiring:

**Danger!**

The positive and negative poles of the output of the battery assembly shall not be connected inversely, and the positive and negative inputs of the corresponding JKP-100LN-BA shall be connected after the polarity is measured and determined with a multimeter.

Step 1: Measure the open-circuit voltage of the battery assembly with a multimeter to ensure it is within the allowable range.

Step 2: Confirm the positive and negative terminals of the voltage using the multimeter.

Step 3: Strip the insulation at the end of the cable.

Step 4: Crimp the wiring copper terminal. Insert the stripped copper core into the wire pressing hole of the terminal and tightly crimp the terminal using appropriate tools. Ensure at least two crimps are made.

Step 5: Install the heat shrinkable sleeve. Choose a sleeve that matches the cable size and is approximately 5 cm in length. Slide the heat shrinkable sleeve over the terminal to completely cover the wire pressing hole, then use a hot blower to shrink the sleeve and secure the DC terminal assembly.

Step 6: Connect the positive cable from the battery assembly to the DC+ terminal of the chassis.

Step 7: Connect the DC- terminal of the JKP-100LN-BA to the negative output of the battery assembly as described in Step 6.

Step 8: Ensure all connections are secure and firmly in place. AC side wiring

2.8. AC Side Wiring:

**Danger!**

When connecting to the AC power grid, ensure that the circuit breaker in the AC distribution cabinet is disconnected to prevent the AC wire connected to the terminal from becoming energized.

Step 1: Use a multimeter to confirm that the connection terminal is powered off.

Step 2: Determine the phase sequence of the AC connection cables.

Step 3: Strip the insulation from the end of the cable.

Step 4: Crimp the wiring copper terminal. Insert the exposed copper core of the stripped cable into the wire pressing hole of the terminal and use tools to tightly crimp the terminal. Ensure that no more than two crimping actions are performed.

Step 5: Install the heat shrinkable sleeve. Choose a sleeve that fits the cable size and is approximately 5 cm in length. Slide the sleeve over the wiring copper terminal to completely cover the wire pressing hole, then use a hot blower to shrink the sleeve and secure the connection.

Step 6: Connect the "L1," "L2," and "L4" cables to the corresponding A (U), B (V), C (W), and N phases of the AC terminal block in the PCS, ensuring that the phase sequence is correct

2.9. Grounding connection



Danger!

As the individual devices in the JKP-100LN-BA require grounding, do not alter the PE copper bar connection wire without proper authorization to avoid the risk of electric shock!

To ensure safety, JKP-100LN-BA must be grounded through PE conductor connected to both the cabinet's grounding bar (Figure 6.1) and the inverter chassis (Figure 6.2).

Two grounding points are located at the back of the inverter unit. Connecting one of these grounding points to the grounding bar is sufficient. Refer to (Figure 7.1) for additional guidance.

The minimum cross-sectional area for the PE cable is 25mm².

Bolts: M8

Torque: 15±1N·m

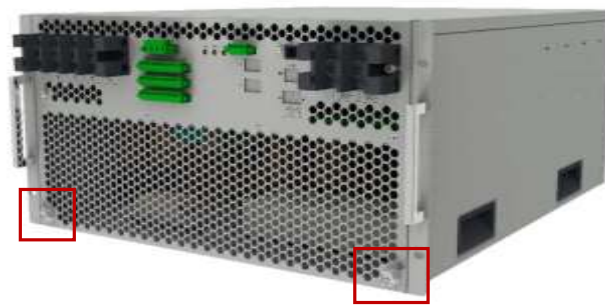

Figure 5.1 Location of the PCSs earth grounding points (backside view)

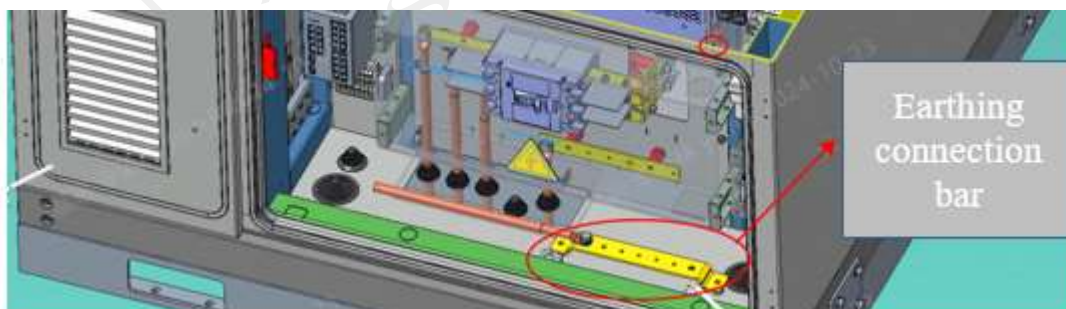

Figure 5.2: Location of the cabinet's earth grounding bar (cabinet frontside view)

NOTE: When PE connection is carried out, it is necessary to reliably connect the PE grounding copper bar with the equipotential connection device in the installation site or electrical control room. The grounding resistance shall not be higher than 1 Ω.

This inverter complies with IEC 62109-2 clause 13.9 for earth fault monitoring alarm. If an Earth Fault Alarm occurs, the red color LED indicator will light up on the front door of the SunGiga system cabinet.

3. Installation and Wiring Checklist

To ensure the safe and reliable operation of the JKP-100LN-BA, please verify its installation according to the items listed in the following table before putting it into operation, ensuring correct installation. Refer to the Table 6-1 and Figure 6.1 and 6.2.

Table 6-1 Installation Checklist

Mechanical Inspection Items	
1	JKP-100LN-BA has no deformation or damage
2	The fixation and support of JKP-100LN-BA lug are stable and reliable
3	JKP-100LN-BA has enough space around
4	The temperature, humidity and ventilation of the environment in which JKP-100LN-BA is located meet the requirements
5	The cooling air circulates smoothly
6	The sealing protection of cabinet body is complete and reliable
Electrical Installation Inspection	
1	JKP-100LN-BA grounding is complete and firm
2	The Power grid voltage matches with JKP-100LN-BA rated output voltage
3	The phase sequence of Power grid connection is correct, and the fastening torque meets the requirements
4	The positive and negative poles of DC input are connected correctly, and the fastening torque meets the requirements
5	The communication wiring is correct and keeps a certain distance from other cables
6	Cable number is marked correctly and clearly
7	The insulation shield is complete and reliable, and the danger warning sign is clear
Other Inspections	
1	All useless conductive parts are tightened with insulating cable ties
2	There are no tools, parts, conductive dust or other foreign matters left behind in the interior
3	There is no condensation of moisture or ice inside



Figure 6.1: Completed wiring of the JKP-100LN-BA (back side view)

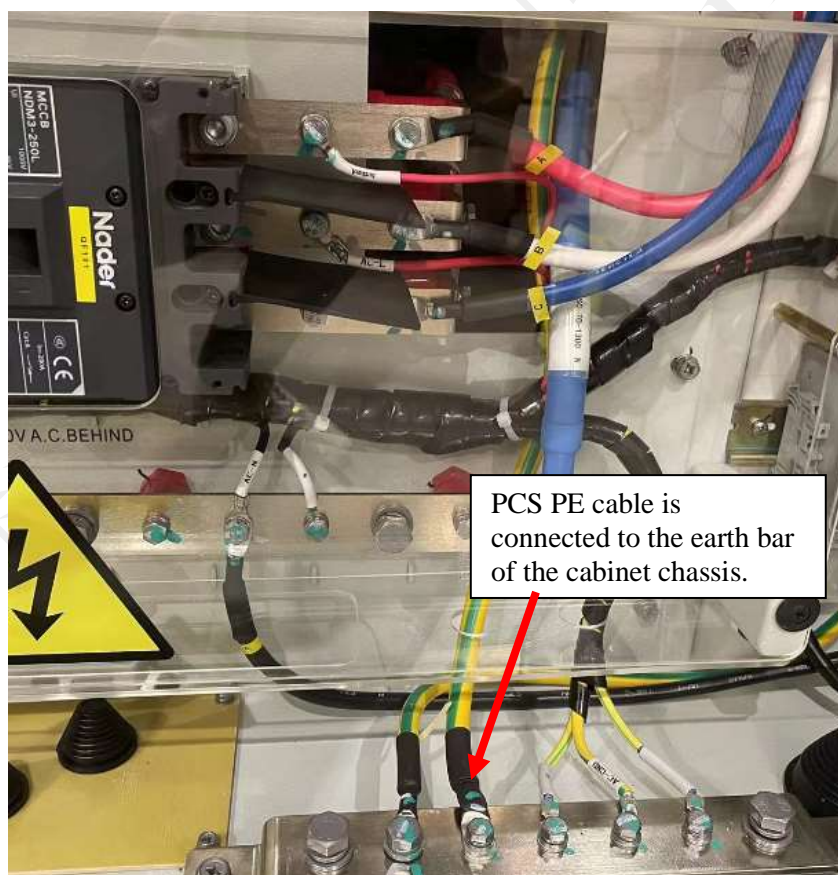

Figure 6.2: Earth bar of the cabinet chassis JKP-100LN-BA (front side view)

4. Start-up and Shutdown Process

Before operation, thoroughly check the equipment installation, ensuring DC and AC terminal voltages meet JKP-100LN-BA requirements, the correct polarity, and compliance with relevant standards. Also, verify proper grounding of the system

4.1. Pre-Operation Checks

Step 1: Verify the installation and wiring of the Power Conversion System as per Section 6.

Step 2: Ensure that the DC circuit breakers are in the open position.

Step 3: Check the Voltage of the Power Grid

Step 4: Verify that the three-phase connection identification of JKP-100LN-BA matches the three-phase identification of the power grid.

Step 5: Ensure that the voltage of the power grid lines is within the specified range and record the voltage values.

Step 6: Check that the power grid frequency is within the specified range and record the frequency value.

Step 7: Measure the Total Harmonic Distortion (THD) of the power grid voltage. If the distortion is significant, JKP-100LN-BA may not operate properly. Check DC side voltage

Step 8: Connect the DC side from the bus box or DC distribution cabinet to the JKP-100LN-BA.

Step 9: Ensure the DC input polarity is correct;

Step 10: Measure and record DC (open circuit) voltage, which does not exceed the maximum allowable DC voltage.

4.2. Start-up Steps

Step 1: After confirming that all previous inspections are normal, power on the DC side and perform DC power transmission outside the cabinet. Then, power on the AC side and manually close the AC side circuit breaker.

Step 2: After about 1 minute, some electrical parameters on the AC and DC sides can be viewed through the upper computer software.

Step 3: Confirm whether the device status is normal: the fault warning light should be off, and there should be no fault display on the LCD main interface.

Step 4: Enter the background software to set the relevant operation parameters. If there is a touchscreen, set the equipment to "start" after parameter setting is completed.

Step 5: After about 10 seconds, the equipment will start up. You may hear the sound of the contactor closing, which is normal. If the equipment is not in use for a long time, it will enter the grid-connected "standby" status.

Step 6: Once JKP-100LN-BA is running (indicated by the running indicator light), check for any abnormalities, such as unusual noise, odors, or smoke. If any of these occur, stop the machine immediately for inspection.

4.3. Normal Shutdown Steps:

Step 1: Set the system to shutdown status via the background software. This will initiate the automatic shutdown process.

Step 2: Once the IGBTs are off, the system will automatically disconnect the AC and DC side contactors. You will hear the contactors disconnecting.

Step 3: Disconnect the AC power by switching off the primary power supply from the AC side outside the cabinet.

Step 4: Disconnect the DC power by switching off the primary power supply from the DC side outside the cabinet.

Step 5: Open the cabinet door and use an electroscope to check for any residual power. Ensure the system is fully discharged before proceeding with any further operations.

Step 6: Confirm that the grounding wire is securely connected.

Step 7: Once the system is safely powered down and discharged, maintenance personnel can begin their maintenance and overhaul operations.

5. Remote Control from the Computer

5.1. Establishing Connection

Step 1: Connect the COM1 port of PCS to the computer via Ethernet cable, and configure the corresponding IP address of the computer as 192.168.0.XX.

Step 2: On the login interface, choose “language-English”, choose “User-User”, enter the password 123, choose “network-192.168.0.20”, and choose “PCS-INPPCS-100-OS”, then click login.



Step 3: When the username and password are correct, you can successfully log in to the main interface. Then click the “login” button in the upper left corner of the interface to enter the parameter setting mode.



5.2. Parameter Check and Setting

In the main interface of the host computer, click “Param Setting” to enter the parameter setting interface.



5.3. Power Grid code/region

In the “Product Export Country” field of the parameter setting interface, you can view and select the grid region (country) where the product will be exported. This selection ensures that the device settings comply with the specific electrical standards and regulations of the chosen region.

5.4. Power Grid Protection

All grid protection parameters are located in the 'Param Setting' interface. These values can be adjusted in the corresponding fields. The default values are listed in the table below.

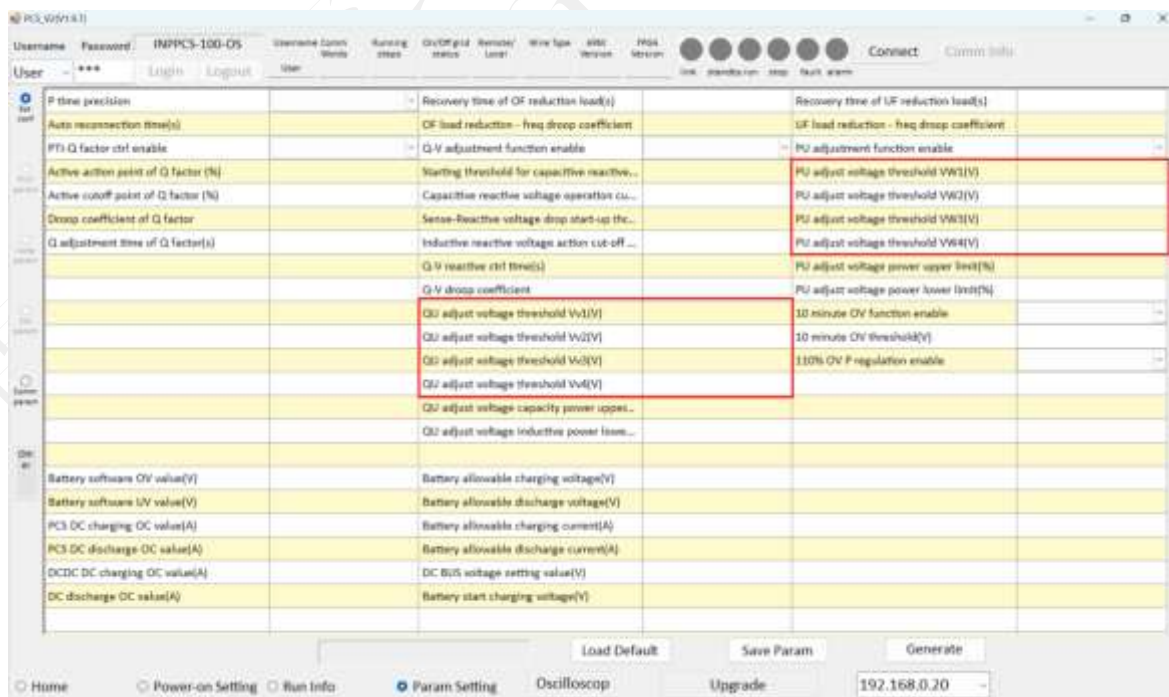

QU adjust voltage threshold Vv1(V)	207.0
QU adjust voltage threshold Vv2(V)	220.0
QU adjust voltage threshold Vv3(V)	240.0

QU adjust voltage threshold Vv4(V)	258.0
PU adjust voltage threshold VW1(V)	207.0
PU adjust voltage threshold VW1(V)	215.0
PU adjust voltage threshold VW1(V)	253.0
PU adjust voltage threshold VW1(V)	260.0

To view and modify other grid protection parameters, you need to obtain the administrator password and log in with administrator privileges. Once logged in, click the "Prot param" sub-interface on the left side of the "Param Setting" interface to access the settings for viewing and modifying additional protection parameters. The default values are listed in the table below.

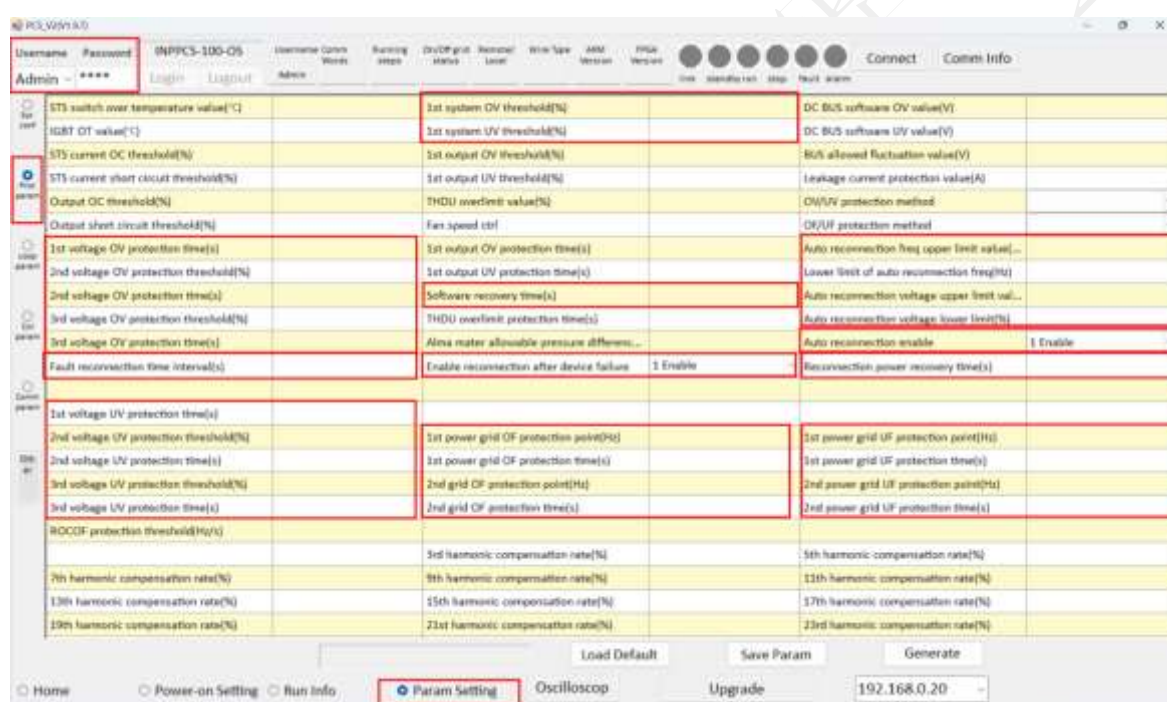

1st system OV threshold(%)	1.13
1st voltage OV protection time(s)	3.0
2nd voltage OV protection threshold(%)	1.15
2nd voltage OV protection time(s)	3.0
3rd voltage OV protection threshold(%)	1.18
3rd voltage OV protection time(s)	0.1
1st system UV threshold(%)	0.79
1st voltage UV protection time(s)	2.0
2nd voltage UV protection threshold(%)	0.3

2nd voltage UV protection time(s)	2.0
3rd voltage UV protection threshold(%)	0.1
3rd voltage UV protection time(s)	2.0
1st power grid OF protection point(Hz)	52.00
1st power grid OF protection time(s)	0.1
2nd grid OF protection point(Hz)	53.00
2nd grid OF protection time(s)	0.1
1st power grid UF protection point(Hz)	46.5
1st power grid UF protection time(s)	1.0
2nd power grid UF protection point(Hz)	46.0
2nd power grid UF protection time(s)	0.2
Software recovery time(s)	2.0

Fault automatic reconnection is disabled by default. The PCS device receives EMS scheduling for on/off operation. If fault automatic reconnection is enabled, the default parameters are as follows:

Auto reconnection enable	0 Prohibit/1 Enable
Enable reconnection after device failure	0 Prohibit/1 Enable
Fault reconnection time interval(s)	300.0
Reconnection power recovery time(s)	10.0
Auto reconnection voltage upper limit value(%)	1.1
Auto reconnection voltage lower limit(%)	0.8
Auto reconnection freq upper limit value(Hz)	50.15
Lower limit of auto reconnection freq(Hz)	47.70

5.5. Power Quality Response Mode

Click the 'Power-on Setting' button at the bottom of the interface using the mouse to enter the power-on settings screen. In this interface, you can configure the power quality response settings.

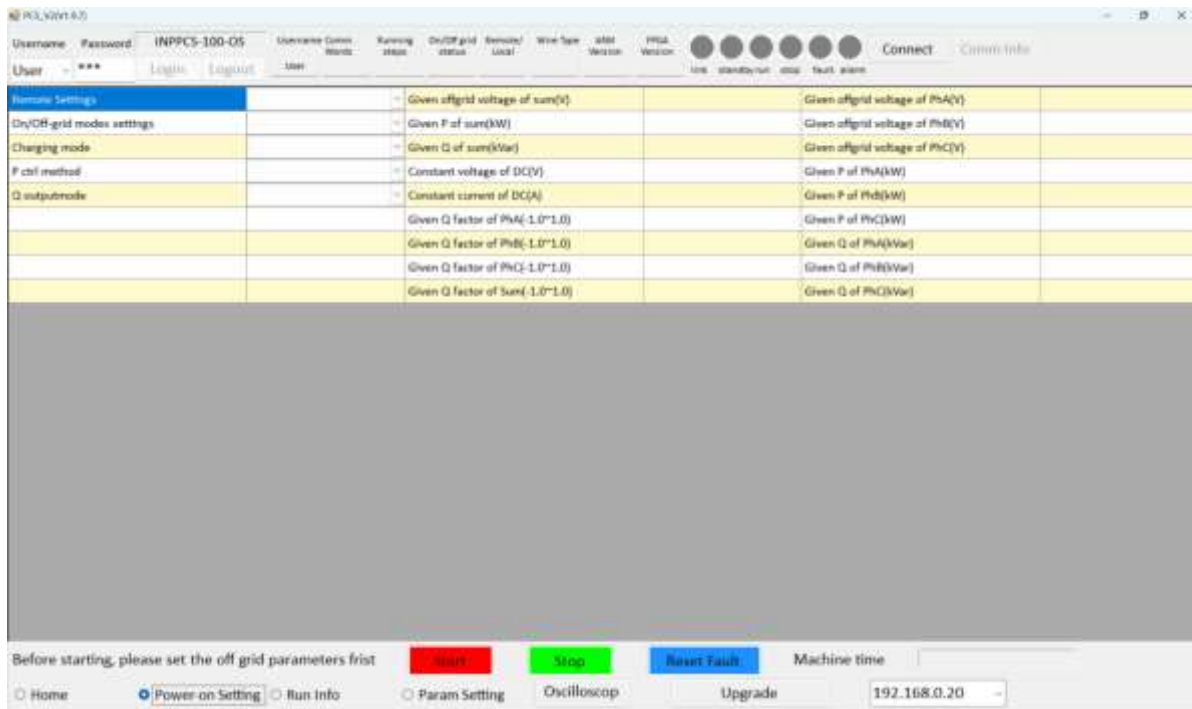

5.6. PCS Firmware Version

The firmware versions need to be checked on the HOME interface. They are displayed in the "ARM Version," "FPGA Version," and "Communication Board Version Number" fields.

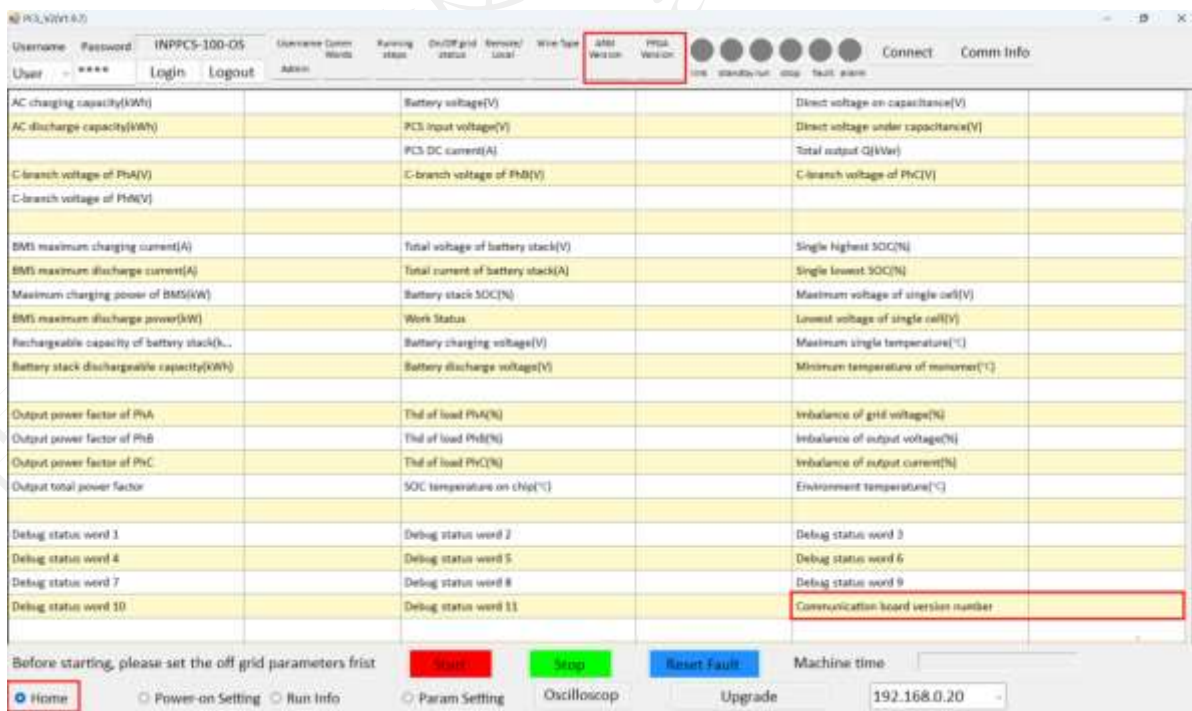

6. Transportation

When transporting the JKP-100LN-BA, users must adhere to the transportation methods outlined in the user manual. It is important to consider the weight and off-center gravity of the unit during transportation.





The JKP-100LN-BA is packed and transported in cartons. Always use both hands or a spreader to grasp the handles.

Note 1: The JKP-100LN-BA should remain intact during transportation and installation. Disassembling the unit or modifying it without Jinko's authorization will void the warranty.

Note 2: Avoid tilting, shaking, or subjecting the Power Conversion System to sudden impacts, such as abrupt lowering or lifting, during transport.

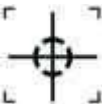
Note 3: Carefully review the marked parameters to ensure the appropriate transportation method and storage location are selected.

To ensure the JKP-100LN-BA is adequately protected during transport, always transport it in its packaging. Follow the various signs on the packaging as indicated. The illustration of packaging signs is shown below.

Icon	Sign
	Gravity center mark
	Face up: It is forbidden to lay, tilt or invert the Power Conversion System horizontally
	Handle with care, to avoid damage to the Power Conversion System caused by excessive collision and friction in transportation environment
	Guard against damp, to avoid rain or damp on the Power Conversion System

7. Storage

After the product acceptance, if the equipment cannot be installed and operated immediately and needs to be stored, the following guidelines should be followed:

- a) Restore the packaging to its original condition.
- b) Keep the desiccant in the package and do not discard it.
- c) Ensure proper ventilation and moisture prevention in the storage area, avoiding water accumulation.
- d) Storage temperature: -20°C to $+70^{\circ}\text{C}$; storage humidity: 0-95% (without condensation).
- e) Protect the equipment from harsh environmental conditions, such as sudden temperature changes, quenching, or collisions, to prevent damage.
- f) It is recommended to inspect the package weekly for integrity and check for insect damage. If the package is damaged, it should be replaced immediately.
- g) If the storage period exceeds six months, open the package for inspection and then repackage the equipment.

8. Maintenance and Repair



First, disconnect the JKP-100LN-BA from both the battery assembly and the Power grid. Once it is confirmed that these power sources will not be reconnected, wait for at least 60 minutes before performing any maintenance or repair operations

Disconnecting from Power Grid and Battery

First, disconnect the JKP-100LN-BA from both the AC Power grid and the battery assembly to ensure that it cannot be accidentally reconnected. Next, switch off the AC side upstream circuit breaker and the battery side circuit breaker. Use a multimeter to confirm that the JKP-100LN-BA is completely disconnected and that no voltage remains. Even after disconnecting from the Power grid and the battery assembly, certain components (e.g., capacitors) may still retain residual voltage and discharge slowly. Therefore, wait at least 20 minutes before proceeding with any further operation after disconnecting the equipment.

Maintenance and Modification

Only personnel authorized by Jinko are allowed to perform maintenance or modifications on the JKP-100LN-BA. For safety reasons, always use the original accessories provided by the manufacturer. Using non-original parts may compromise electrical safety and compliance with EMC standards, voiding relevant certifications and warranties.

Functional and Safety Parameters

Do not alter the JKP-100LN-BA parameters without prior approval from Jinko. Unauthorized changes to functional or safety parameters may lead to injury or damage to both personnel and equipment.

9. Routine Maintenance



Danger!

All maintenance operations must be performed with the switches on the DC side, AC side, battery module, and AC distribution cabinet of the JKP-100LN-BA fully disconnected.

Even after disconnecting the JKP-100LN-BA DC switch, some components within the unit may still retain residual voltage. Wait at least 60 minutes before proceeding with any maintenance to prevent the risk of electric shock!

To ensure the normal operation and longevity of the JKP-100LN-BA, it is essential to perform regular maintenance. The recommended routine maintenance cycle and the corresponding tasks are outlined in the table below.

Table 12-1 Routine Maintenance Cycle Work Contents

Maintenance Item	Cycle
Clean the dust at the air inlet of the Power module	Every month
Check whether there is dust, moisture or condensed water vapor inside the box	Every month
Check whether the cable connection is loose and tighten the screws if necessary	Every month
Check warning signs and add or replace them if necessary	Every month
Manually check DC breakers	Every six months
Check the stop function of LCD	Every month
Check whether there is abnormal noise during the operation of the equipment	Every month

9.1. Waste disposal

At the end of its service life, users should dispose of the unit in accordance with local laws and regulations and must not discard it irresponsibly.

10. Technical Parameter

Model		JKP-100LN-BA
DC Side	Max. DC voltage [Vd.c.]	900
	Min. DC voltage [Vd.c.]	630
	DC voltage range [Vd.c.]	630 V-900
	Max. DC current [Ad.c.]	175
	Rated DC power [kW]	100
	Max. DC power [kW]	110
	Overvoltage Category (OVC)	II
	Rated conditional short- circuit current [Ad.c.]	Consider fuse characteristics given in Section 2.1
AC Side (Grid)	AC rated Input /Output active Power P_E [kW]	100
	AC rated Input /Output apparent Power P_E [kVA]	100
	Max. AC Input/Output current [Aa.c.]	160
	Nominal AC voltage U_r [Va.c.]	3L/N/PE, 400 /230
	AC voltage tolerance	-15%- +15%
	Nominal frequency/Frequency F_{NETZ} [Hz]	50 /60
	Harmonic (THDi)	≤5% (at nominal Power), Linear load
	Power factor	-0.99-+0.99, At nominal Power
	Adjustable reactive Power range	-100%–100%
	Overvoltage Category (OVC)	III
	Rated conditional short- circuit current [Aa.c.]	Phase-to-ground ~330A Phase-to-phase ~430A
System Parameters	Type of Inverter	Non-isolated
	Battery Type	Li-ion Battery
	Max. efficiency	>98%
	Communication	RS485, CAN, Ethernet
	Enclosure Dimensions (W * H * D)	480 mm × 260 mm × 620 mm, (Cabinet size)
	Weight	70kg

Degree of protection	IP20
Operating ambient temperature [°C]	-25-60 (>45 derating)
Allowable relative humidity	RH ≤95%
Cooling method	Forced air cooling
Max. operating altitude	4,000 m (>2,000 m derating)
Pollution degree	2

Notes

This PCS is compliant with IEC 62109-1:2010 Clause 4.4.4.6 and Clause 5.3.2 j and has no backfeed current.

11. Quality Assurance

Warranty period

The warranty period for this product is five years. If otherwise stipulated in the contract, the contract shall prevail.

During the warranty period of Jinko products, customers should take the initiative to show the invoice and date of purchasing products to Jinko service personnel during maintenance. At the same time, the nameplate on the product shall be clearly visible, otherwise Jinko has the right to refuse repair.

Warranty conditions

Jinko will repair or replace the products that fail during the warranty period free of charge. The faulty equipment shall be owned by Jinko Co., Ltd. after replacement. The customer should reserve a certain time for Jinko Co., Ltd. to repair the faulty equipment.

Exemption from liability.

Our products only support on-grid operation and do not support off-grid operation. Therefore, there is no need to connect an external contactor or use any other means to control.

Our company has the right not to provide warranty services under the following circumstances:

- a) The product has no Jinko logo;
- b) The product or components have exceeded the warranty period;
- c) Failure or damage (such as too high temperature, too low temperature, too wet or dry environment, too high altitude and unstable voltage or current) caused by failure to meet the requirements of the instruction manual, non-working environment specified by the product or wrong installation, storage and use;
- d) Failure or damage caused by installation, repair, alteration or disassembly by non- Jinko after-sales service personnel, except those entrusted by Jinko after-sales service;
- e) Failure or damage caused by the use of non- Jinko components;
- f) Failure or damage caused by accident or man-made reasons (such as operation error, scratch, handling, bumping and inappropriate voltage connection), or transportation damage;
- g) Failure or damage caused by force majeure such as natural disasters (such as earthquake, lightning strike and fire);

Other failures or damages not caused by quality problems of Jinko equipment (including components).